

Periodic solutions of a differential perturbed system via the averaging theory and the Melnikov method

Sana Karfes  ¹ and Elbahi Hadidi ¹

¹Laboratory of Applied Mathematics, Badji Mokhtar-Annaba University, P.O. Box 12, Annaba, 23000, Algeria.

Received 1 February 2023, Accepted 18 June 2023, Published 29 June 2023

Abstract. In this paper, we will study the maximum number of limit cycles of a perturbed differential system with respect to its parameters, especially on the degree of the polynomials. For this, we will use two methods namely the averaging theory of first order and the Melnikov method on the same system to see the periodic solutions which can bifurcate from the center with $\varepsilon = 0$. In the end, we will present some numerical examples to illustrate the theoretical results given by both Methods.

Keywords: Differential system, Periodic solution, Averaging theory, Melnikov's method.

2020 Mathematics Subject Classification: 58A15, 34C25.

1 Introduction

This work focuses on the qualitative theory of nonlinear planar differential systems. Hilbert's 16th Problem consists in determining the maximum number H_n of limit cycles of a polynomial system of degree n , the phenomenon of limit cycles was discovered and studied for the first time by Poincaré [15, 16], who defined the limit cycle as an isolated periodic orbit in the set of all the periodic orbits of a differential system. The classic method of producing limit cycles is to perturb a system that has a center, as we will do in this paper. Among the methods used to determine the maximum number of limit cycles is the averaging theory of first order and Melnikov's method, which are two powerful tools in the study of different types of dynamical systems (see [1, 3, 5, 6, 11, 13, 17, 18] and the references therein). The purpose of this work is to apply two methods on the same system to compare them. The system that we are going to study is a perturbed center given as follows

$$\begin{cases} \dot{x} = y + \varepsilon(1 + \sin^m(\theta)) \sum_{i+j=0}^n \mu_{ij} x^i y^j, \\ \dot{y} = -x, \end{cases} \quad (1.1)$$

[✉]Corresponding author. Email: sana.karfes@gmail.com

where $\varepsilon > 0$ is a small parameter, m is an arbitrary non-negative integer, and $\tan(\theta) = \frac{y}{x}$. This system is a kind of generalization of the second-order differential equation of Mathieu, which is the simplest model of an excited system depending on parameters (see [12]). Several authors are interested in studying the number of periodic solutions of a differential system with respect to its parameters, which appear in the system, especially on the degree of the polynomials (see [8–10]).

2 Fundamental tools

Before starting our discussion on the study of limit cycles, we need some preliminary notions that we will see in this section.

Theorem 2.1 (Averaging theory of first order). *Consider a non-autonomous differential equation of the form*

$$\frac{dr}{d\theta} = \chi(r, \theta) = \varepsilon F(r, \theta) + \varepsilon^2 R(r, \theta, \varepsilon), \quad (2.1)$$

where $r \in \mathbb{R}$, $\theta \in S^1 = \mathbb{R}/(2\pi\mathbb{Z})$ and $F : D \times S^1 \rightarrow \mathbb{R}^2$, $R : D \times S^1 \times (-\varepsilon_0, \varepsilon_0) \rightarrow \mathbb{R}^2$ are \mathbb{C}^2 function, 2π -periodic in the variable θ and D is an open interval of \mathbb{R} . The averaged function $f : D \rightarrow \mathbb{R}$ associated with the system (2.1) is defined by

$$f(r) = \frac{1}{2\pi} \int_0^{2\pi} F(r, \theta) d\theta.$$

We called that if $r(r_0, \theta)$ is the solution of the vector field $\chi(r, \theta)$ such that $r(r_0, 0) = r_0$, then we have

$$r(r_0, 2\pi) - r_0 = \varepsilon f(r) + O(\varepsilon^2).$$

So for $\varepsilon > 0$ sufficiently small, the simple zeros of the averaged function $f(r)$ provide limit cycles of vector field $\chi(r, \theta)$, see [4, 11].

Theorem 2.2. *Consider the differential system*

$$\dot{X} = f(X) + \varepsilon g(X, \mu), \quad (2.2)$$

where $f \in C^1(\mathbb{R}^2)$ and $g \in C^1(\mathbb{R}^2 \times \mathbb{R}^m)$. For $\varepsilon = 0$, the system (2.2) has a one-parameter family of periodic orbits $\gamma_r(\theta)$ of period T_r on the interior of Γ_0 with $\frac{\partial \gamma_r(0)}{\partial r} \neq 0$, if there exists a point $(r_0, \mu_0) \in \mathbb{R}^{m+1}$ such that the function

$$M(r, \mu) = \int_0^{T_r} f(\gamma_r(\theta)) \wedge g[\gamma_r(\theta), \mu] d\theta.$$

Satisfies

$$M(r_0, \mu_0) = 0 \quad \text{and} \quad M_r(r_0, \mu_0) \neq 0.$$

then for all sufficiently small $\varepsilon \neq 0$, the system (2.2) with $\mu = \mu_0$ has a unique hyperbolic limit cycle in $O(\varepsilon)$ neighborhood of the cycle $\gamma_{r_0}(\theta)$. If $M(r_0, \mu_0) \neq 0$, then for sufficiently small $\varepsilon \neq 0$ the system

$$M_{m,n}(\theta_0) = \int_0^{mT} f(\gamma_r(\theta)) \wedge g[\gamma_r(\theta), \theta + \theta_0] d\theta.$$

with $\mu = \mu_0$ has no cycle in an $O(\varepsilon)$ neighborhood of the cycle $\gamma_{r_0}(\theta)$, See [14].

Next, in order to calculate the averaged function and the Melnikov one, we will use the following formulas, see [7].

$$\int_0^{2\pi} \cos^p(\theta) \sin^{2q}(\theta) d\theta = \frac{(2q-1)!!}{(2q+p)(2q+p-2)\dots(p+2)} \int_0^{2\pi} \cos^p(\theta) d\theta, \quad (2.3)$$

$$p \in \mathbb{R} \setminus \{-2, -4, \dots\}, \quad q \in \mathbb{N},$$

$$\int_0^{2\pi} \cos^p(\theta) \sin^{2q+1}(\theta) d\theta = 0, \quad p \in \mathbb{R} \setminus \{-1, -3, \dots\}, \quad q \in \mathbb{N}. \quad (2.4)$$

$$\int_0^{2\pi} \cos^{2l}(\theta) d\theta = \frac{(2l-1)!!}{2^l l} 2\pi, \quad l > 0, \quad (2.5)$$

$$\int_0^{2\pi} \cos^{2l+1}(\theta) d\theta = 0, \quad l \geq 0, \quad (2.6)$$

Remark 2.3. In order to study the simple zeros of the averaged function and the Melnikov one, we shall apply the Descartes Theorem.

Theorem 2.4 (Descartes Theorem). *Let us consider the real polynomial*

$$p(r) = a_{i_1} r^{i_1} + a_{i_2} r^{i_2} + \dots + a_{i_n} r^{i_n},$$

with $0 \leq i_1 < i_2 < \dots < i_n$ and $a_{i_j} \neq 0$ real constants for $j \in (1, 2, \dots, n)$. When $a_{i_j} a_{i_{j+1}} < 0$, we say that a_{i_j} and $a_{i_{j+1}}$ have a variation of the sign. If the number of variations of the signs is m , then $p(r)$ has at most m positive real zeros. In addition, it is always possible to choose the coefficients of $p(r)$ in such a way that $p(r)$ has exactly $n - 1$ positive zeros.

For the proof, see [2].

3 Periodic solutions via averaging theory

Our first main contribution will be presented in the next theorem.

Theorem 3.1. *Suppose that the averaged function $f(r)$ of the first order is non-zero and $\varepsilon > 0$ is small enough. The maximum number of limit cycles bifurcating from the periodic solutions of the center is at most :*

- a) $\frac{n-2}{2}$ if n and m are even.
- b) $\frac{n-1}{2}$ if n is odd and m is even.
- c) $n - 1$ if m and n are odd.
- d) $n - 1$ if m is odd and n is even.

3.1 Proof

The system (1.1) in polar coordinates is written as follows :

$$\begin{cases} \dot{r} = \varepsilon(1 + \sin^m(\theta)) \sum_{i+j=0}^n \mu_{ij} r^{i+j} \cos^{i+1}(\theta) \sin^j(\theta), \\ \dot{\theta} = -1 - \varepsilon(1 + \sin^m(\theta)) \sum_{i+j=0}^n \mu_{ij} r^{i+j-1} \cos^i(\theta) \sin^{j+1}(\theta). \end{cases}$$

Taking θ as the new independent variable, the previous differential system becomes the differential equation

$$\begin{aligned}\frac{dr}{d\theta} &= \frac{\varepsilon(1 + \sin^m(\theta)) \sum_{i+j=0}^n \mu_{ij} r^{i+j} \cos^{i+1}(\theta) \sin^j(\theta)}{-1 - \varepsilon(1 + \sin^m(\theta)) \sum_{i+j=0}^n \mu_{ij} r^{i+j-1} \cos^i(\theta) \sin^{j+1}(\theta)} \\ \frac{dr}{d\theta} &= -\varepsilon(1 + \sin^m(\theta)) \sum_{i+j=0}^n \mu_{ij} r^{i+j} \cos^{i+1}(\theta) \sin^j(\theta) + O(\varepsilon^2). \\ \frac{dr}{d\theta} &= \varepsilon F(r, \theta) + O(\varepsilon^2).\end{aligned}\tag{3.1}$$

Remark 3.2. This differential equation is written in standard form (2.1).

Remark 3.3. The calculation of $f(r)$ depends on m and n .

Case (a) If n and m are even.

$$\begin{aligned}f_1(r) &= \frac{1}{2\pi} \int_0^{2\pi} F(r, \theta) d\theta \\ &= \frac{-1}{2\pi} \int_0^{2\pi} (1 + \sin^m(\theta)) \sum_{i+j=0}^n \mu_{ij} r^{i+j} \cos^{i+1}(\theta) \sin^j(\theta) d\theta \\ &= \frac{-1}{2\pi} \int_0^{2\pi} \left[\sum_{i+j=0}^n \mu_{ij} r^{i+j} \cos^{i+1}(\theta) \sin^j(\theta) + \right. \\ &\quad \left. + \sum_{i+j=0}^n \mu_{ij} r^{i+j} \cos^{i+1}(\theta) \sin^{j+m}(\theta) \right] d\theta \\ &= \frac{-1}{2\pi} \left[\int_0^{2\pi} \sum_{2p+j=2}^{n+1} \mu_{2p-1,j} r^{2p-1+j} \cos^{2p}(\theta) \sin^j(\theta) d\theta + \right. \\ &\quad \left. + \int_0^{2\pi} \sum_{2p+j=2}^{n+1} \mu_{2p-1,j} r^{2p-1+j} \cos^{2p}(\theta) \sin^{j+m}(\theta) d\theta \right] \\ &= \frac{-1}{2\pi} \sum_{2p+2q=2}^n \mu_{2p-1,2q} r^{2p+2q-1} \times \\ &\quad \times \left[\int_0^{2\pi} (\cos^{2p}(\theta) \sin^{2q}(\theta) + \cos^{2p}(\theta) \sin^{2q+m}(\theta)) d\theta \right] \\ &= \frac{-1}{2\pi} \sum_{p+q=1}^{\frac{n}{2}} \mu_{2p-1,2q} r^{2(p+q)-1} \times \\ &\quad \times \left[\frac{(2q-1)!!}{(2q+2p)(2q+2p-2)\dots(2p+2)} \frac{(2p-1)!!}{2^p p!} 2\pi + \right. \\ &\quad \left. + \frac{(2q+m-1)!!}{(2q+m+2p)(2q+m+2p-2)\dots(2p+2)} \frac{(2p-1)!!}{2^p p!} 2\pi \right] \\ &= \sum_{k=1}^{\frac{n}{2}} A_k r^{2k-1}.\end{aligned}$$

Case (b) If n is odd and m is even.

$$\begin{aligned}
 f_2(r) &= \frac{1}{2\pi} \int_0^{2\pi} F(r, \theta) d\theta \\
 &= \frac{-1}{2\pi} \int_0^{2\pi} (1 + \sin^m(\theta)) \sum_{i+j=0}^n \mu_{ij} r^{i+j} \cos^{i+1}(\theta) \sin^j(\theta) d\theta \\
 &= \frac{-1}{2\pi} \left[\int_0^{2\pi} \sum_{i+j=0}^n \mu_{ij} r^{i+j} \cos^{i+1}(\theta) \sin^j(\theta) d\theta + \right. \\
 &\quad \left. + \int_0^{2\pi} \sum_{i+j=0}^n \mu_{ij} r^{i+j} \cos^{i+1}(\theta) \sin^{j+m}(\theta) d\theta \right] \\
 &= \frac{-1}{2\pi} \sum_{2p+2q=2}^{n+1} \mu_{2p-1, 2q} r^{2p+2q-1} \times \\
 &\quad \times \left[\int_0^{2\pi} \cos^{2p}(\theta) \sin^{2q}(\theta) d\theta + \int_0^{2\pi} \cos^{2p}(\theta) \sin^{2q+m}(\theta) d\theta \right] \\
 &= \frac{-1}{2\pi} \sum_{2p+2q=2}^{n+1} \mu_{2p-1, 2q} r^{2p+2q-1} \times \\
 &\quad \times \left[\frac{(2q-1)!!}{(2q+2p)(2q+2p-2)\dots(2p+2)} \frac{(2p-1)!!}{2^p p!} 2\pi + \right. \\
 &\quad \left. + \frac{(2q+m-1)!!}{(2q+m+2p)(2q+m+2p-2)\dots(2p+2)} \frac{(2p-1)!!}{2^p p!} 2\pi \right] \\
 &= - \sum_{p+q=1}^{\frac{n+1}{2}} \mu_{2p-1, 2q} r^{2(p+q)-1} \times \\
 &\quad \times \left[\frac{(2q-1)!!}{(2q+2p)(2q+2p-2)\dots(2p+2)} \frac{(2p-1)!!}{2^p p!} + \right. \\
 &\quad \left. + \frac{(2q+m-1)!!}{(2q+m+2p)(2q+m+2p-2)\dots(2p+2)} \frac{(2p-1)!!}{2^p p!} \right] \\
 &= \sum_{k=1}^{\frac{n+1}{2}} B_k r^{2k-1}.
 \end{aligned}$$

Case (c) If n and m are odd.

$$\begin{aligned}
 f_3(r) &= \frac{1}{2\pi} \int_0^{2\pi} F(r, \theta) d\theta \\
 &= \frac{-1}{2\pi} \int_0^{2\pi} (1 + \sin^m(\theta)) \sum_{i+j=0}^n \mu_{ij} r^{i+j} \cos^{i+1}(\theta) \sin^j(\theta) d\theta \\
 &= \frac{-1}{2\pi} \left[\int_0^{2\pi} \sum_{i+j=0}^n \mu_{ij} r^{i+j} \cos^{i+1}(\theta) \sin^j(\theta) d\theta + \right. \\
 &\quad \left. + \int_0^{2\pi} \sum_{i+j=0}^n \mu_{ij} r^{i+j} \cos^{i+1}(\theta) \sin^{j+m}(\theta) d\theta \right]
 \end{aligned}$$

$$\begin{aligned}
&= \frac{-1}{2\pi} \left[\sum_{2p+2q=2}^{n+1} \mu_{2p-1,2q} r^{2p+2q-1} \int_0^{2\pi} \cos^{2p}(\theta) \sin^{2q}(\theta) d\theta + \right. \\
&+ \left. \sum_{2p+2q+1=3}^n \mu_{2p-1,2q+1} r^{2p+2q} \int_0^{2\pi} \cos^{2p}(\theta) \sin^{2q+m+1}(\theta) d\theta \right] \\
&= \frac{-1}{2\pi} \left[\sum_{2p+2q=2}^{n+1} \mu_{2p-1,2q} r^{2p+2q-1} \times \right. \\
&\times \frac{(2q-1)!!}{(2q+2p)(2q+2p-2)\dots(2p+2)} \frac{(2p-1)!!}{2^p p!} 2\pi + \\
&+ \sum_{2p+2q=2}^{n-1} \mu_{2p-1,2q+1} r^{2p+2q} \times \\
&\times \left. \frac{(2q+m+1-1)!!}{(2q+m+1+2p)(2q+m+1+2p-2)\dots(2p+2)} \frac{(2p-1)!!}{2^p p!} 2\pi \right] \\
&= \frac{-1}{2\pi} \left[\sum_{p+q=1}^{\frac{n+1}{2}} \mu_{2p-1,2q} r^{2p+2q-1} \times \right. \\
&\times \frac{(2q-1)!!}{(2q+2p)(2q+2p-2)\dots(2p+2)} \frac{(2p-1)!!}{2^p p!} + \\
&+ \sum_{p+q=1}^{\frac{n-1}{2}} \mu_{2p-1,2q+1} r^{2p+2q} \times \\
&\left. \frac{(2q+m+1-1)!!}{(2q+m+1+2p)(2q+m+1+2p-2)\dots(2p+2)} \frac{(2p-1)!!}{2^p p!} 2\pi \right] \\
&= \sum_{k=1}^n C_k r^k.
\end{aligned}$$

Case (d) If n is even and m is odd.

$$\begin{aligned}
f_4(r) &= \frac{1}{2\pi} \int_0^{2\pi} F(r, \theta) d\theta \\
&= \frac{-1}{2\pi} \int_0^{2\pi} (1 + \sin^m(\theta)) \sum_{i+j=0}^n \mu_{ij} r^{i+j} \cos^{i+1}(\theta) \sin^j(\theta) d\theta \\
&= \frac{-1}{2\pi} \left[\int_0^{2\pi} \sum_{i+j=0}^n \mu_{ij} r^{i+j} \cos^{i+1}(\theta) \sin^j(\theta) d\theta \right. \\
&+ \left. \int_0^{2\pi} \sum_{i+j=0}^n \mu_{ij} r^{i+j} \cos^{i+1}(\theta) \sin^{j+m}(\theta) d\theta \right] \\
&= \frac{-1}{2\pi} \left[\sum_{2p+2q=2}^n \mu_{2p-1,2q} r^{2p+2q-1} \int_0^{2\pi} \cos^{2p}(\theta) \sin^{2q}(\theta) d\theta \right. \\
&+ \left. \sum_{2p+2q+1=3}^{n+1} \mu_{2p-1,2q+1} r^{2p+2q} \int_0^{2\pi} \cos^{2p}(\theta) \sin^{2q+m+1}(\theta) d\theta \right]
\end{aligned}$$

$$\begin{aligned}
 &= \frac{-1}{2\pi} \left[\sum_{p+q=1}^{\frac{n}{2}} \mu_{2p-1,2q} r^{2(p+q)-1} \times \right. \\
 &\quad \times \frac{(2q-1)!!}{(2q+2p)(2q+2p-2)\dots(2p+2)} \frac{(2p-1)!!}{2^p p!} 2\pi + \\
 &\quad + \sum_{p+q=1}^{\frac{n}{2}} \mu_{2p-1,2q+1} r^{2(p+q)} \times \\
 &\quad \left. \times \frac{(2q+m-1-1)!!}{(2q+m+1+2p)(2q+m+1+2p-2)\dots(2p+2)} \frac{(2p-1)!!}{2^p p!} 2\pi \right] \\
 &= \sum_{k=1}^n D_k r^k.
 \end{aligned}$$

4 Periodic solutions via Melnikov's method

Our second main contribution will be presented in the next theorem.

Theorem 4.1. *Suppose that the Melnikov function is non-zero and for all sufficiently small $\varepsilon \neq 0$. The maximum number of limit cycles bifurcating from periodic solutions of a center is at most :*

- a) $\frac{n-2}{2}$ if n and m are even.
- b) $\frac{n-1}{2}$ if n is odd and m is even.
- c) $n-1$ if m and n are odd.
- d) $n-1$ if m is odd and n is even.

4.1 Proof

Consider the system which takes the following form:

$$\dot{X} = f(X) + \varepsilon g(X, \mu), \quad X \in \mathbb{R}^2,$$

where $f \in C^1(\mathbb{R}^2)$, $g \in C^1(\mathbb{R}^2 \times \mathbb{R}^m)$ and $\varepsilon \neq 0$ sufficiently small. The unperturbed system for $\varepsilon = 0$:

$$\dot{X} = f(X) \tag{4.1}$$

has a center at the origin with a one-parameter family of periodic orbits $\gamma_r(\theta)$ of period T_r on

the interior of Γ_0 with $\frac{\partial \gamma_r(0)}{\partial r} \neq 0$.

Melnikov's function is given as:

$$M(r, \mu) = \int_0^{T_r} \exp\left(-\int_0^\theta \nabla f(\gamma_r(s)) ds\right) f(\gamma_r(\theta)) \wedge g[\gamma_r(\theta), \mu] d\theta.$$

Remark 4.2. If for $\varepsilon = 0$, (4.1) is a Hamiltonian system i.e, if $f = \left(\frac{\partial H}{\partial y}, -\frac{\partial H}{\partial x}\right)^T$. Then, $\nabla f = 0$ and the Melnikov function has the simplest form

$$M(r, \mu) = \int_0^{T_r} f(\gamma_r(\theta)) \wedge g[\gamma_r(\theta), \mu] d\theta. \tag{4.2}$$

Proof. $f = (H_y, -H_x)^T \implies \nabla f = \text{div}(f) = \frac{\partial}{\partial x} H_y - \frac{\partial}{\partial y} H_x = 0.$ □

Remark 4.3. The wedge product of two vectors $u = (u_1, u_2)^T$ and $v = (v_1, v_1)^T \in \mathbb{R}^2$ is defined as

$$u \wedge v = u_1 v_2 - v_1 u_2$$

Our considered system (1.1) takes the form (2.2), for $f = (y, -x)^T$ and

$$g = \left((1 + \sin^m(\theta)) \sum_{i+j=0}^n \mu_{ij} x^i y^j, 0 \right)^T, \text{ where } g \text{ is a } 2\pi\text{-periodic function.}$$

For $\varepsilon = 0$, the system has a center at the origin with a one-parameter family of periodic orbits

$\gamma_r(\theta) = (r \cos(\theta), -r \sin(\theta))^T$ of period $T_r = 2\pi$. By replacing f and g in (4.2), we get:

$$\begin{aligned} M(r, \mu) &= \int_0^{2\pi} (y, -x)^T \wedge \left((1 + \sin^m(\theta)) \sum_{i+j=0}^n \mu_{ij} x^i y^j, 0 \right)^T [\gamma_r(\theta), \mu] d\theta \\ &= \int_0^{2\pi} x(1 + \sin^m(\theta)) \sum_{i+j=0}^n \mu_{ij} x^i y^j d\theta \\ &= \int_0^{2\pi} (1 + \sin^m(\theta)) x \sum_{i+j=0}^n \mu_{ij} x^i y^j d\theta \\ &= \int_0^{2\pi} (1 + \sin^m(\theta)) \sum_{i+j=0}^n \mu_{ij} x^{i+1} y^j d\theta \end{aligned}$$

By performing the change of variables such as $x = r \cos(\theta)$ and $y = r \sin(\theta)$, we find:

$$\begin{aligned} M(r, \mu) &= \int_0^{2\pi} (1 + \sin^m(\theta)) \sum_{i+j=0}^n \mu_{ij} r^{i+1} \cos^{i+1}(\theta) r^j \sin^j(\theta) d\theta \\ &= \int_0^{2\pi} \left[\sum_{i+j=0}^n \mu_{ij} r^{i+j+1} \cos^{i+1}(\theta) \sin^j(\theta) + \right. \\ &\quad \left. + \sum_{i+j=0}^n \mu_{ij} r^{i+j+1} \cos^{i+1}(\theta) \sin^{j+m}(\theta) \right] d\theta \\ &= \int_0^{2\pi} \sum_{i+j=0}^n \mu_{ij} r^{i+j+1} \cos^{i+1}(\theta) \sin^j(\theta) d\theta \\ &\quad + \int_0^{2\pi} \sum_{i+j=0}^n \mu_{ij} r^{i+j+1} \cos^{i+1}(\theta) \sin^{j+m}(\theta) d\theta \end{aligned}$$

Remark 4.4. The calculation of $M(r, \mu)$ depends on m and n .

Case (a) If m and n are even.

$$\begin{aligned} M_1(r, \mu) &= \int_0^{2\pi} \sum_{i+j=0}^n \mu_{ij} r^{i+j+1} \cos^{i+1}(\theta) \sin^j(\theta) d\theta + \\ &\quad + \int_0^{2\pi} \sum_{i+j=0}^n \mu_{ij} r^{i+j+1} \cos^{i+1}(\theta) \sin^{j+m}(\theta) d\theta \end{aligned}$$

$$\begin{aligned}
 &= \int_0^{2\pi} \sum_{2p+2q=2}^n \mu_{2p-1,2q} r^{2p+2q} \cos^{2p}(\theta) \sin^{2q}(\theta) d\theta + \\
 &+ \int_0^{2\pi} \sum_{2p+2q=2}^n \mu_{2p-1,2q} r^{2p+2q} \cos^{2p}(\theta) \sin^{2q+m}(\theta) d\theta \\
 &= \sum_{2p+2q=2}^n \mu_{2p-1,2q} r^{2p+2q} \times \\
 &\times \left[\int_0^{2\pi} (\cos^{2p}(\theta) \sin^{2q}(\theta) + \cos^{2p}(\theta) \sin^{2q+m}(\theta)) d\theta \right] \\
 &= \sum_{p+q=1}^{\frac{n}{2}} \mu_{2p-1,2q} r^{2p+2q} \times \\
 &\times \left[\frac{(2q-1)!!}{(2q+2p)(2q+2p-2)\dots(2p+2)} \frac{(2p-1)!!}{2^p p!} 2\pi + \right. \\
 &\left. + \frac{(2q+m-1)!!}{(2q+m+2p)(2q+m+2p-2)\dots(2p+2)} \frac{(2p-1)!!}{2^p p!} 2\pi \right] \\
 &= 2\pi \sum_{k=1}^{\frac{n}{2}} \tilde{A}_k r^{2k}
 \end{aligned}$$

Case (b) If m is even and n is odd.

$$\begin{aligned}
 M_2(r, \mu) &= \int_0^{2\pi} \sum_{i+j=0}^n \mu_{ij} r^{i+j+1} \cos^{i+1}(\theta) \sin^j(\theta) d\theta + \\
 &+ \int_0^{2\pi} \sum_{i+j=0}^n \mu_{ij} r^{i+j+1} \cos^{i+1}(\theta) \sin^{j+m}(\theta) d\theta \\
 &= \int_0^{2\pi} \sum_{2p+2q=2}^{n+1} \mu_{2p-1,2q} r^{2p+2q} \cos^{2p}(\theta) \sin^{2q}(\theta) d\theta + \\
 &+ \int_0^{2\pi} \sum_{2p+2q=2}^{n+1} \mu_{2p-1,2q} r^{2p+2q} \cos^{2p}(\theta) \sin^{2q+m}(\theta) d\theta \\
 &= \sum_{2p+2q=2}^{n+1} \mu_{2p-1,2q} r^{2p+2q} \times \\
 &\times \left[\int_0^{2\pi} (\cos^{2p}(\theta) \sin^{2q}(\theta) + \cos^{2p}(\theta) \sin^{2q+m}(\theta)) d\theta \right] \\
 &= \sum_{2p+2q=2}^{n+1} \mu_{2p-1,2q} r^{2p+2q} \times \\
 &\times \left[\int_0^{2\pi} (\cos^{2p}(\theta) \sin^{2q}(\theta) + \cos^{2p}(\theta) \sin^{2q+m}(\theta)) d\theta \right] \\
 &= \sum_{p+q=1}^{\frac{n+1}{2}} \mu_{2p-1,2q} r^{2p+2q} \times \\
 &\times \left[\frac{(2q-1)!!}{(2q+2p)(2q+2p-2)\dots(2p+2)} \frac{(2p-1)!!}{2^p p!} 2\pi + \right.
 \end{aligned}$$

$$\begin{aligned}
& + \frac{(2q+m-1)!!}{(2q+m+2p)(2q+m+2p-2)\dots(2p+2)} \frac{(2p-1)!!}{2^p p!} 2\pi \Big] \\
& = 2\pi \sum_{k=1}^{\frac{n+1}{2}} \tilde{B}_k r^{2k}
\end{aligned}$$

Case (c) If m and n are odd

$$\begin{aligned}
M_3(r, \mu) &= \int_0^{2\pi} \sum_{i+j=0}^n \mu_{ij} r^{i+j+1} \cos^{i+1}(\theta) \sin^j(\theta) d\theta + \\
&+ \int_0^{2\pi} \sum_{i+j=0}^n \mu_{ij} r^{i+j+1} \cos^{i+1}(\theta) \sin^{j+m}(\theta) d\theta \\
&= \int_0^{2\pi} \sum_{2p+2q=2}^{n+1} \mu_{2p-1,2q} r^{2p+2q} \cos^{2p}(\theta) \sin^{2q}(\theta) d\theta + \\
&+ \int_0^{2\pi} \sum_{2p+2q+1=3}^n \mu_{2p-1,2q+1} r^{2p+2q+1} \cos^{2p}(\theta) \sin^{2q+m+1}(\theta) d\theta \\
&= \sum_{2p+2q=2}^{n+1} \mu_{2p-1,2q} r^{2p+2q} \int_0^{2\pi} \cos^{2p}(\theta) \sin^{2q}(\theta) d\theta + \\
&+ \sum_{2p+2q=2}^{n-1} \mu_{2p-1,2q+1} r^{2p+2q+1} \int_0^{2\pi} \cos^{2p}(\theta) \sin^{2q+m+1}(\theta) d\theta \\
&= \sum_{2p+2q=2}^{n+1} \mu_{2p-1,2q} r^{2p+2q} \times \\
&\times \frac{(2q-1)!!}{(2q+2p)(2q+2p-2)\dots(2p+2)} \frac{(2p-1)!!}{2^p p!} 2\pi + \\
&+ \sum_{2p+2q=2}^{n-1} \mu_{2p-1,2q+1} r^{2p+2q+1} \times \\
&\times \frac{(2q+m+1-1)!!}{(2q+m+1+2p)(2q+m+1+2p-2)\dots(2p+2)} \times \\
&\times \frac{(2p-1)!!}{2^p p!} 2\pi \\
&= \sum_{p+q=1}^{\frac{n+1}{2}} \mu_{2p-1,2q} r^{2(p+q)} \times \\
&\times \frac{(2q-1)!!}{(2q+2p)(2q+2p-2)\dots(2p+2)} \frac{(2p-1)!!}{2^p p!} 2\pi + \\
&+ \sum_{p+q=1}^{\frac{n-1}{2}} \mu_{2p-1,2q+1} r^{2(p+q)+1} \times \\
&\times \frac{(2q+m)!!}{(2q+m+1+2p)(2q+m+2p-2)\dots(2p+2)} \times \\
&\times \frac{(2p-1)!!}{2^p p!} 2\pi
\end{aligned}$$

$$= 2\pi \sum_{k=2}^{n+1} \tilde{C}_k r^k$$

Case (d) If m is odd and n is even.

$$\begin{aligned} M_4(r, \mu) &= \int_0^{2\pi} \sum_{i+j=0}^n \mu_{ij} r^{i+j+1} \cos^{i+1}(\theta) \sin^j(\theta) d\theta + \\ &+ \int_0^{2\pi} \sum_{i+j=0}^n \mu_{ij} r^{i+j+1} \cos^{i+1}(\theta) \sin^{j+m}(\theta) d\theta \\ &= \int_0^{2\pi} \sum_{2p+2q=2}^n \mu_{2p-1,2q} r^{2p+2q} \cos^{2p}(\theta) \sin^{2q}(\theta) d\theta + \\ &+ \int_0^{2\pi} \sum_{2p+2q+1=3}^{n+1} \mu_{2q-1,q+1} r^{2p+2q+1} \cos^{2p}(\theta) \sin^{2q+m+1}(\theta) d\theta \\ &= \sum_{2p+2q=2}^n \mu_{2p-1,2q} r^{2p+2q} \int_0^{2\pi} \cos^{2p}(\theta) \sin^{2q}(\theta) d\theta + \\ &+ \sum_{2p+2q=2}^n \mu_{2p-1,2q-1} r^{2p+2q+1} \int_0^{2\pi} \cos^{2p}(\theta) \sin^{2q+m+1}(\theta) d\theta \\ &= \sum_{p+q=1}^{\frac{n}{2}} \mu_{2p-1,2q} r^{2p+2q} \times \\ &\times \frac{(2q-1)!!}{(2q+2p)(2q+2p-2)\dots(2p+2)} \frac{(2p-1)!!}{2^p p!} 2\pi + \\ &+ \sum_{p+q=1}^{\frac{n}{2}} \mu_{2p-1,2q-1} r^{2p+2q+1} \times \\ &\times \frac{(2q+m+1-1)!!}{(2q+m+1+2p)(2q+m+1+2p-2)\dots(2p+2)} \times \\ &\times \frac{(2p-1)!!}{2^p p!} 2\pi \\ &= 2\pi \sum_{k=2}^{n+1} \tilde{D}_k r^k \end{aligned}$$

5 Applications and Simulations

Here, four numerical examples are presented to confirm our results.

Example 5.1. Consider the following system

$$\begin{cases} \dot{x} = y + \varepsilon(1 + \sin^4(\theta))(y^2x - x^3y^2 - y^6) \\ \dot{y} = -x, \end{cases} \quad (5.1)$$

here $n = 6$ and $m = 4$, which are even. It corresponds to **case (a)**. The averaged function and the Melnikov one are as follows:

$$\begin{cases} f_1(r) = \frac{1}{256} r^3 (19r^2 - 42), \\ M_1(r) = -\frac{1}{256} r^4 (19r^2 - 42), \end{cases}$$

and as we have

$$\begin{cases} \frac{\partial f_1(\frac{1}{19}\sqrt{798})}{\partial r} = \frac{441}{608}, \\ \frac{\partial M_1(\frac{1}{19}\sqrt{798})}{\partial r} = -\frac{441}{11552}\sqrt{798}, \end{cases}$$

then there is only one limit cycle of amplitude $\frac{1}{19}\sqrt{798} \simeq 1.49$ for the system (5.1). According to the results given by the averaging theory and Melnikov method in the **case (a)** there exists at most $\frac{n-2}{2} = 2$ limit cycles (see figure 5.1).

Example 5.2. Consider the following system

$$\begin{cases} \dot{x} = y + \varepsilon(1 + \sin^4(\theta))(x - x^3)(3x^2 - 5x^4), \\ \dot{y} = -x, \end{cases} \quad (5.2)$$

here $n = 7$ and $m = 4$, where n is odd and m even; this corresponds to **case (b)**. The averaged function and that of Melnikov are as follows:

$$\begin{cases} f_2(r) = -\frac{r^3}{1024}(1453r^4 - 2656r^2 + 1224), \\ M_2(r) = \frac{r^4}{1024}(1435r^4 - 2656r^2 + 1224), \end{cases}$$

and as we have

$$\begin{cases} \frac{\partial f_3(0.9921)}{\partial r} = -0.31941, \\ \frac{\partial M_3(0.9921)}{\partial r} = 0.31688, \end{cases}$$

and

$$\begin{cases} \frac{\partial f_2(0.93087)}{\partial r} = 0.24796, \\ \frac{\partial M_2(0.93087)}{\partial r} = -0.23082, \end{cases}$$

then the system (5.2) has two limit cycles of amplitude 0.99 and 0.93. According to the results given by the averaging theory and Melnikov method in **case (b)** there exists at most $\frac{n-1}{2} = 3$ limit cycle (see figure 5.2).

Example 5.3. Consider the following system

$$\begin{cases} \dot{x} = y + \varepsilon(1 + \sin^3(\theta))(x - x^3)(3x^2 - 5x^4), \\ \dot{y} = -x, \end{cases} \quad (5.3)$$

here $n = 7$ and $m = 3$, where n and m are odd; this corresponds to **case (c)**. The averaged function and that of Melnikov are as follows:

$$\begin{cases} f_3(r) = -\frac{r^3}{128}(175r^4 - 320r^2 + 144), \\ M_3(r) = \frac{r^4}{128}(175r^4 - 320r^2 + 144), \end{cases}$$

and as we have

$$\begin{cases} \frac{\partial f_3(\frac{2}{5}\sqrt{5})}{\partial r} = \frac{2}{5}, \\ \frac{\partial M_3(\frac{2}{5}\sqrt{5})}{\partial r} = -\frac{4}{25}\sqrt{5}, \end{cases}$$

and

$$\begin{cases} \frac{\partial f_3(\frac{6}{35}\sqrt{35})}{\partial r} = -\frac{162}{245}, \\ \frac{\partial M_3(\frac{6}{35}\sqrt{35})}{\partial r} = \frac{972}{8575}\sqrt{35}, \end{cases}$$

then the system (5.3) has two limit cycles of amplitude $\frac{2}{5}\sqrt{5} \simeq 0.89$ et $\frac{6}{35}\sqrt{35} \simeq 1.01$. According to the results given by the averaging theory and Melnikov method in **case (c)** there exists at most $n - 1 = 6$ limit cycles (see figure 5.3).

Example 5.4. Consider the following system

$$\begin{cases} \dot{x} = y + \varepsilon(1 + \sin^3(\theta))(xy - yx^3), \\ \dot{y} = -x, \end{cases} \quad (5.4)$$

here $n = 4$ and $m = 3$, where n is even and m is odd; this corresponds to case **(d)**. The averaged function and that of Melnikov are as follows:

$$\begin{cases} f_4(r) = \frac{r^2}{128}(-8 + 3r^2), \\ M_4(r) = \frac{-r^3}{128}(-8 + 3r^2), \end{cases}$$

and as we have

$$\begin{cases} \frac{\partial f_4(\frac{2}{3}\sqrt{6})}{\partial r} = \frac{1}{12}\sqrt{6}, \\ \frac{\partial M_4(\frac{2}{3}\sqrt{6})}{\partial r} = -\frac{1}{3}, \end{cases}$$

then there is only one limit cycle of amplitude $\frac{2}{3}\sqrt{6} \simeq 1.63$ for the system (5.4). According to the results given by the averaging theory and Melnikov method in **case (d)** there exists at most $n - 1 = 3$ limit cycles (see figure 5.4).

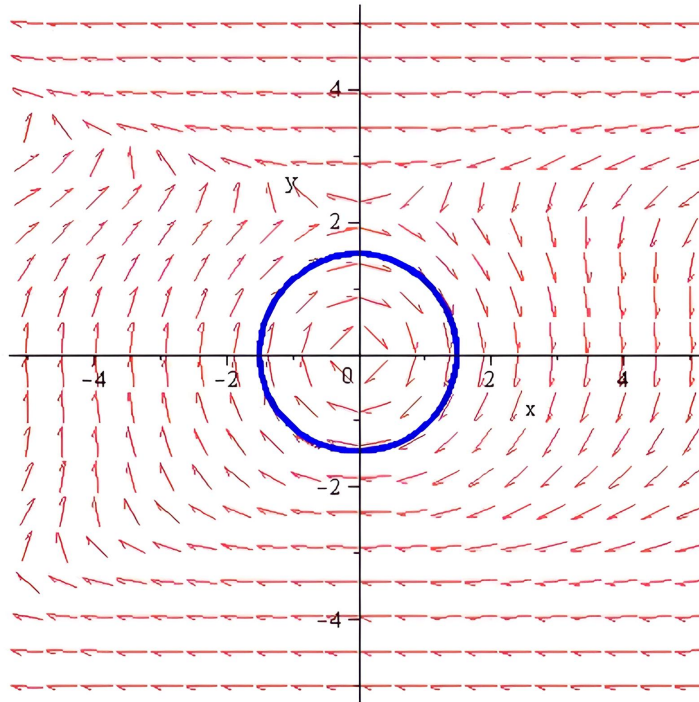

Figure 5.1: Limit cycle of amplitude 1.49 for the system (5.1) when $\varepsilon = 0.01$.

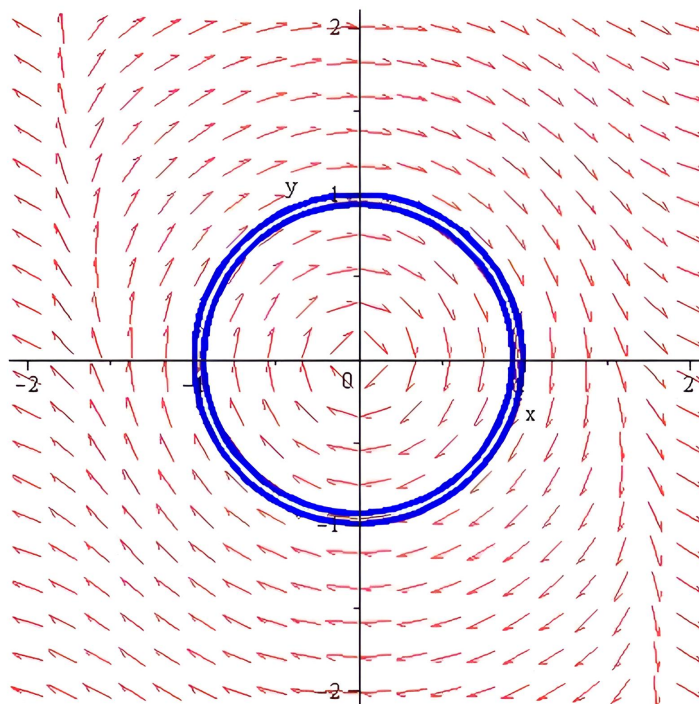

Figure 5.2: Two limit cycles of amplitude 0.99 and 0.93 for the system (5.2) when $\varepsilon = 0.01$.

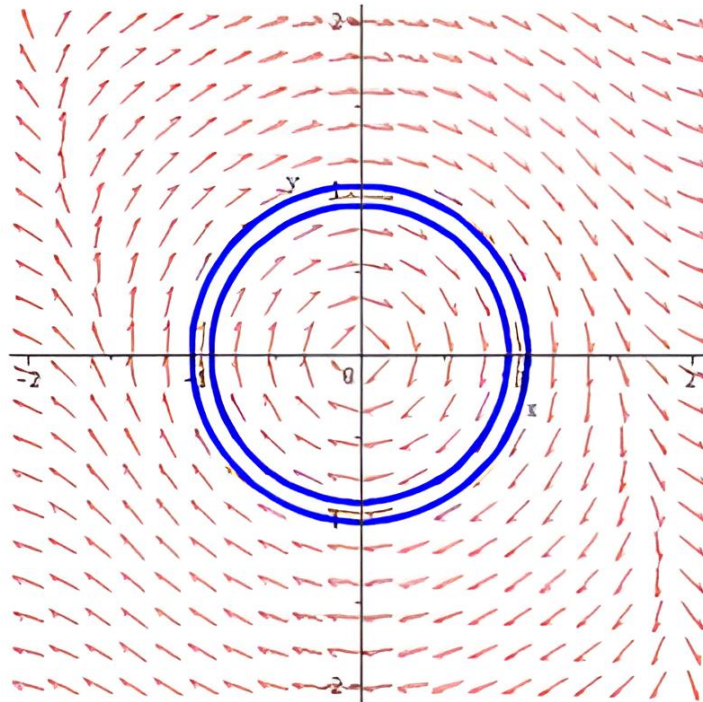

Figure 5.3: Two limit cycles of amplitude 0.89 and 1.01 for the system (5.3) when $\varepsilon = 0.01$.

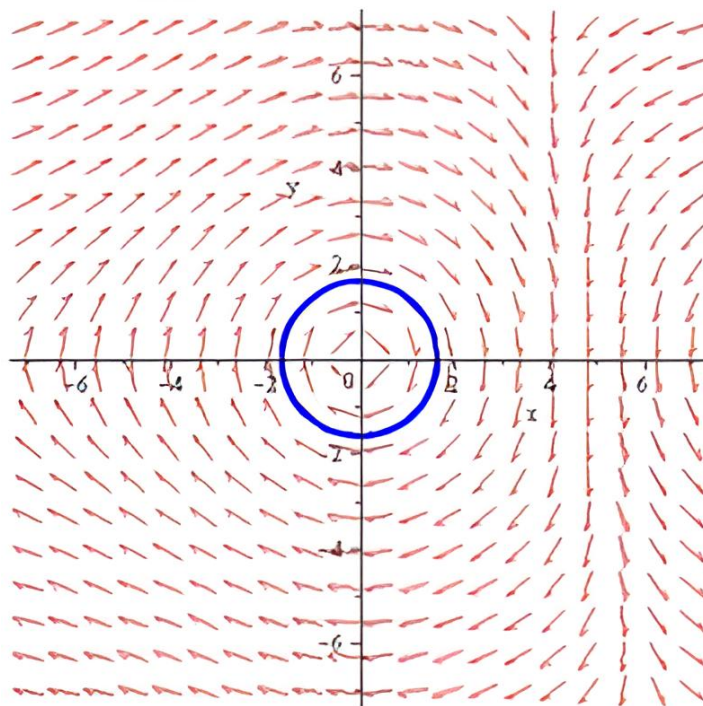

Figure 5.4: Limit cycle of amplitude 1.63 for the system (5.4) when $\varepsilon = 0.01$.

6 Conclusion

In this article, we studied the maximum number of limit cycles of a planar differential system, by using the averaging theory of first order and the Melnikov method. We remark the equivalence between these two methods which appeared clearly in the four cases.

Conflict of interest

The authors have no conflicts of interest to declare.

References

- [1] S. BADI AND A. MAKHLOUF, *Limit cycles of the generalized Liénard differential equation via averaging theory*, *Electronic Journal of Differential Equations*, **68** (2012), 1–11. [URL](#)
- [2] I. S. BEREZIN AND N. P. ZHIDKV, *Computing Methods*, vol. II, Pergamon Press, Oxford, 1964.
- [3] A. BUICA, J. GINÉ AND J. LLIBRE, *Bifurcation of limit cycles from a polynomial degenerate center*, *Advanced Nonlinear Studies*, **10** (2010), 597–609.
- [4] A. BUICA AND J. LLIBRE, *Averaging methods for finding periodic orbits via Brouwer degree*, *Bulletin des Sciences Mathématiques*, **128** (2004), 7–22.
- [5] T. CHEN AND J. LLIBRE, *Limit cycles of a second-order differential equation*, *Applied Mathematics Letters*, **88** (2019) 111–117.
- [6] A. CIMA, J. LLIBRE, AND M. A. TEIXEIRA, *Limit cycles of some polynomial differential system in dimension 2, 3 and 4 via averaging theory*, *Applicable Analysis* **87** (2008), 149–164.
- [7] I. S. GRADSHTEYN AND I. M. RYZHIK, *Table of Integrals, Series, and Products*, (Eighth Edition), Academic Press, 2014. [DOI](#)
- [8] N. HIRANO AND S. RYBICKI, *Existence of limit cycles for coupled van der Pol equations*, *Journal of Differential Equations*, vol. **195**(1) (2003), 194–209. [DOI](#)
- [9] S. KARFES, E. HADIDI AND M. A. KERKER, *On the maximum number of limit cycles of a planar differential system*, *International Journal of Nonlinear Analysis and Applications*, **13**(1) (2022), 1462-1478. [DOI](#)
- [10] J. LLIBRE AND A.C. MEREU, *Limit cycles for generalized Kukles polynomial differential systems*, *Nonlinear Analysis*, **74** (2011), 1261-1271.
- [11] J. LLIBRE, R. MOECKEL, C. SIMÓ, *Central Configurations, Periodic orbits and Hamiltonian systems*, *Advanced Courses in Mathematics CRM Barcelona*, Birkhäuser, 2015.
- [12] E. MATHIEU, *Mémoire sur le mouvement vibratoire d'une membrane de forme elliptique*, *Journal de Mathématiques Pures et Appliquées*, **13** (1868) ' 137–203.
- [13] N. MELLAHI, A. BOULFOUL AND A. MAKHLOUF, *Maximum Number of Limit Cycles for Generalized Kukles Polynomial Differential Systems*, *Differential Equations and Dynamical Systems*, **27** (2019), 493-514.

- [14] L. PERKO, *Differential Equations and Dynamical Systems*. Texts in Applied Mathematics, V. 7, 3rd edition. Springer, New York, 2000.
- [15] H. POINCARÉ, *Mémoire sur les courbes définies par une équation différentielle I*, *Journal de Mathématiques Pures et Appliquées*, **7** (1881), 375–422.
- [16] H. POINCARÉ, *Mémoire sur les courbes définies par une équation différentielle II*, *Journal de Mathématiques Pures et Appliquées*, **8** (1882), 251–296.
- [17] E. SÁEZ AND I. SZÁNTÓ, *Bifurcations of limit cycles in Kukles systems of arbitrary degree with invariant ellipse*, *Applied Mathematics Letters*, **25** (2012), 1695-1700.
- [18] H. SHI, Y. BAI AND M. HAN, *On the maximum number of limit cycles for a piecewise smooth differential system*, *Bulletin des Sciences Mathématiques*, **163** (2020), 102887.